

# Battery connector

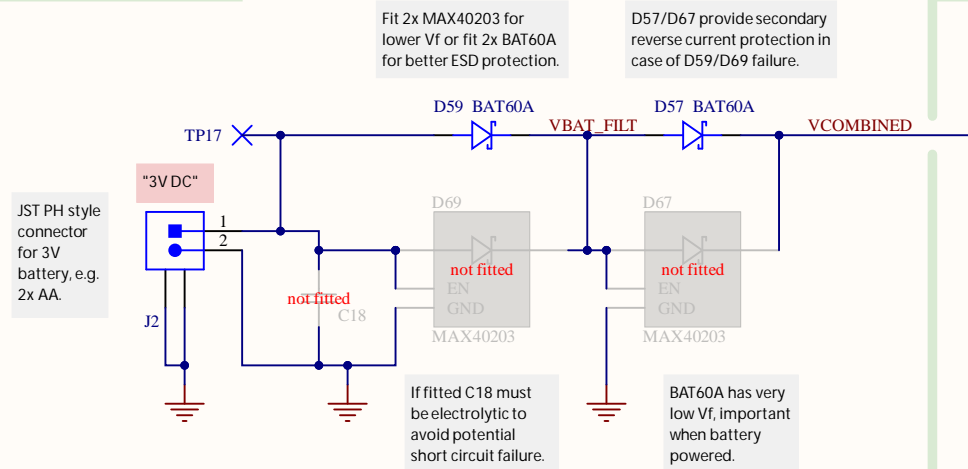

# Regulator

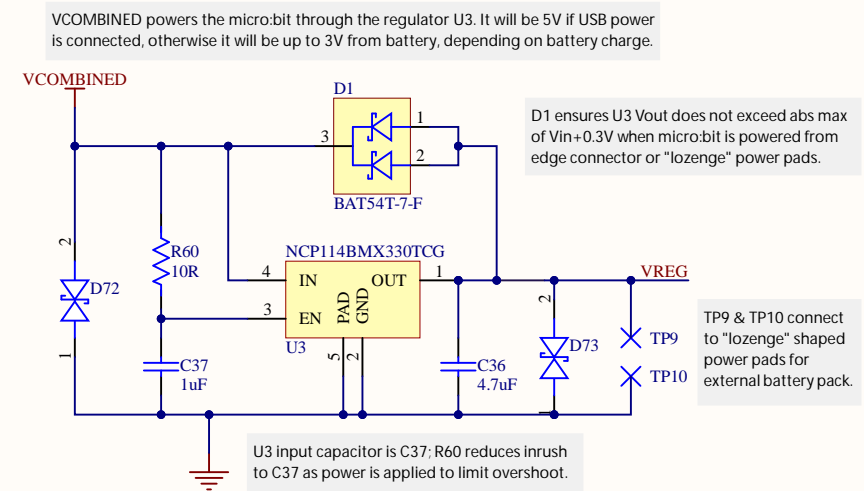

# Interface LEDs

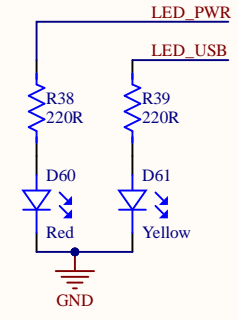

# Hardware revision id

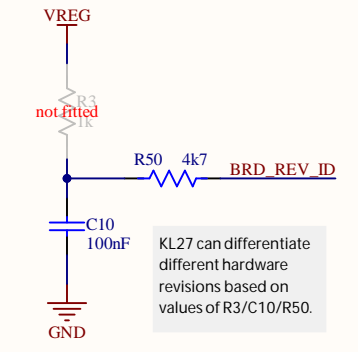

# USB connector

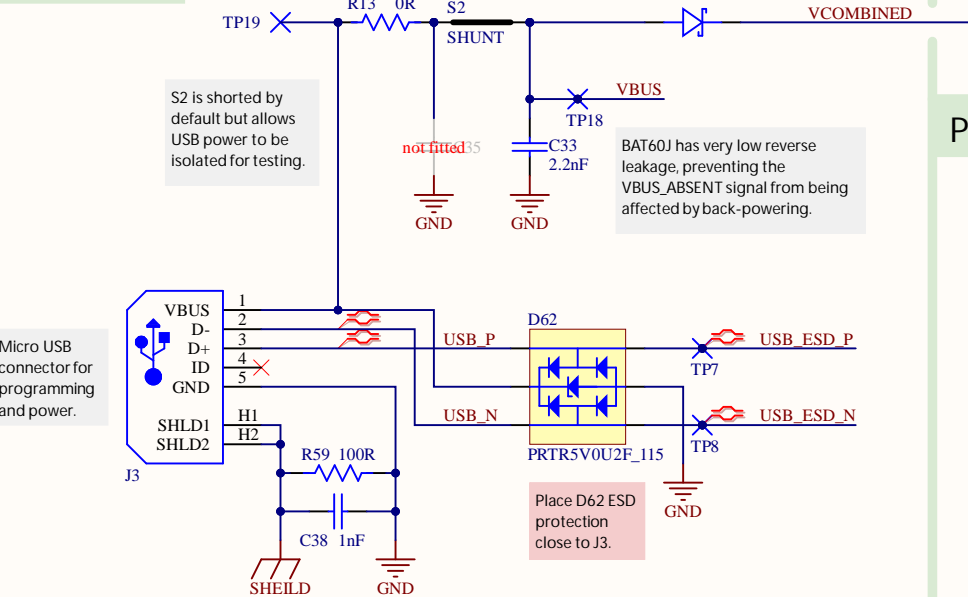

# Power monitoring

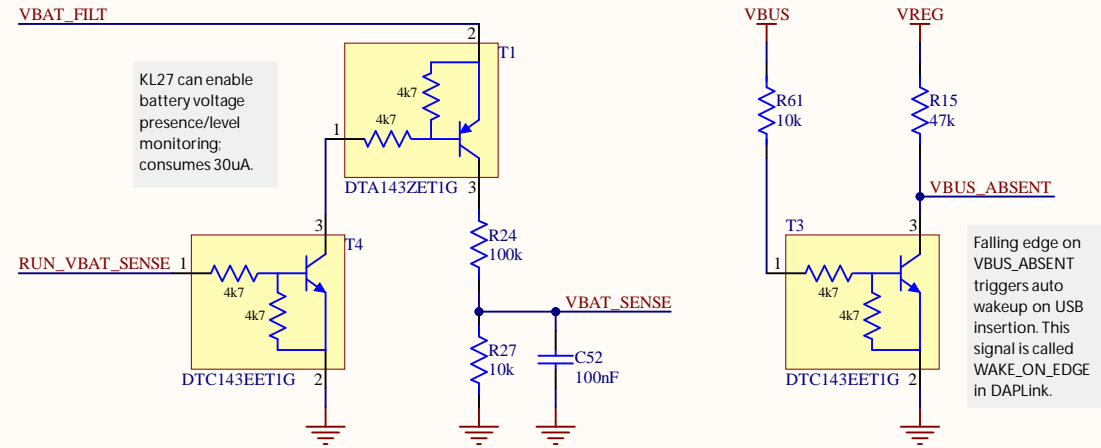

# Reset

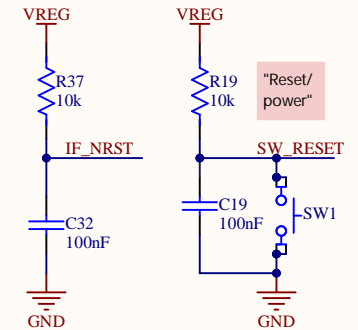

# Interface MCU

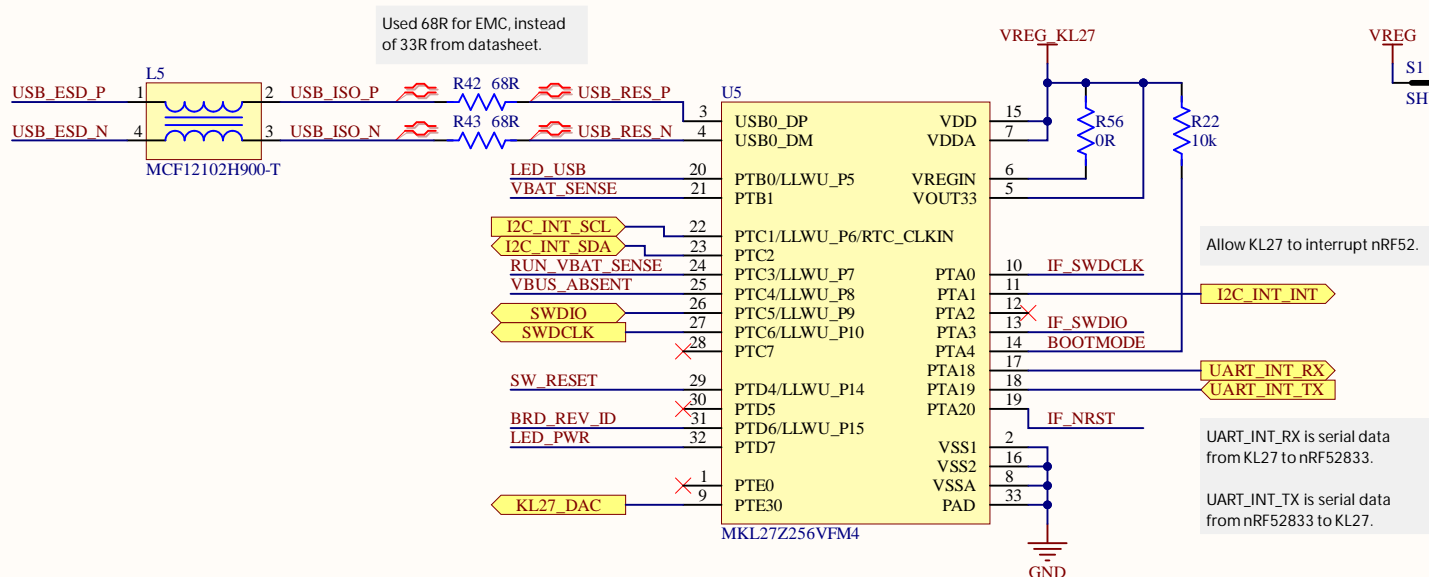

# KL27 debugging

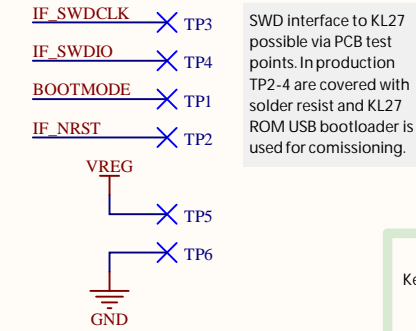

## Speaker

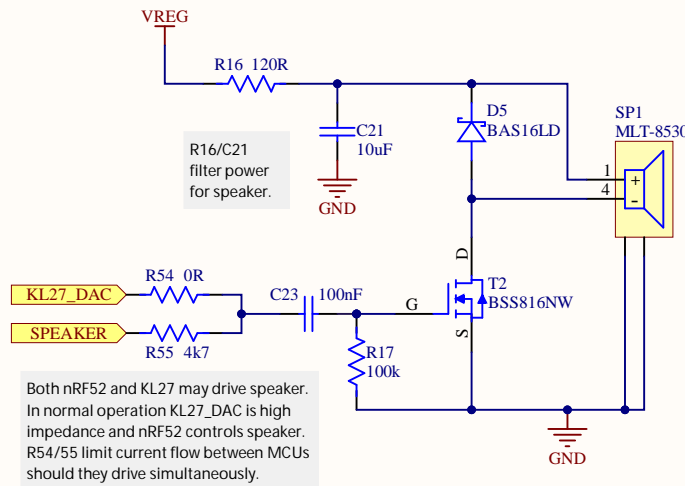

## Microphone

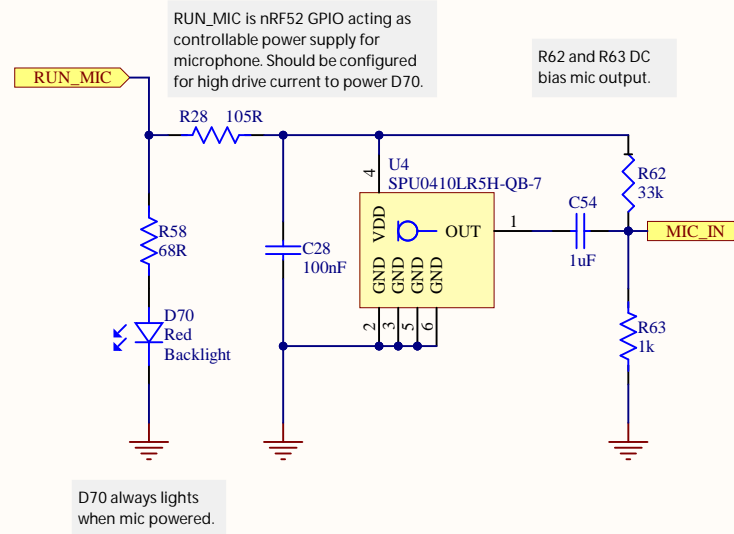

## Buttons

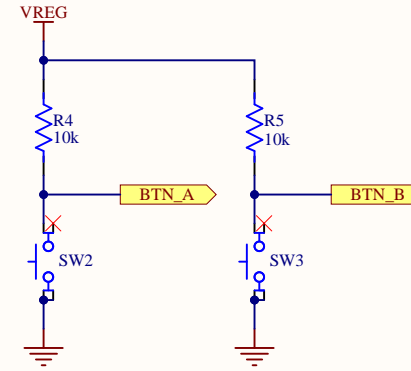

## Touch sensing

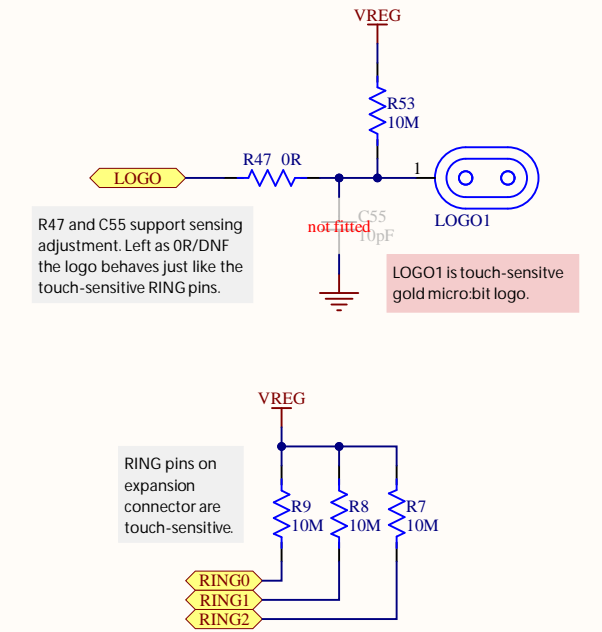

## Motion sensor

U1 & U6 are alternatives, fit one depending on availability.

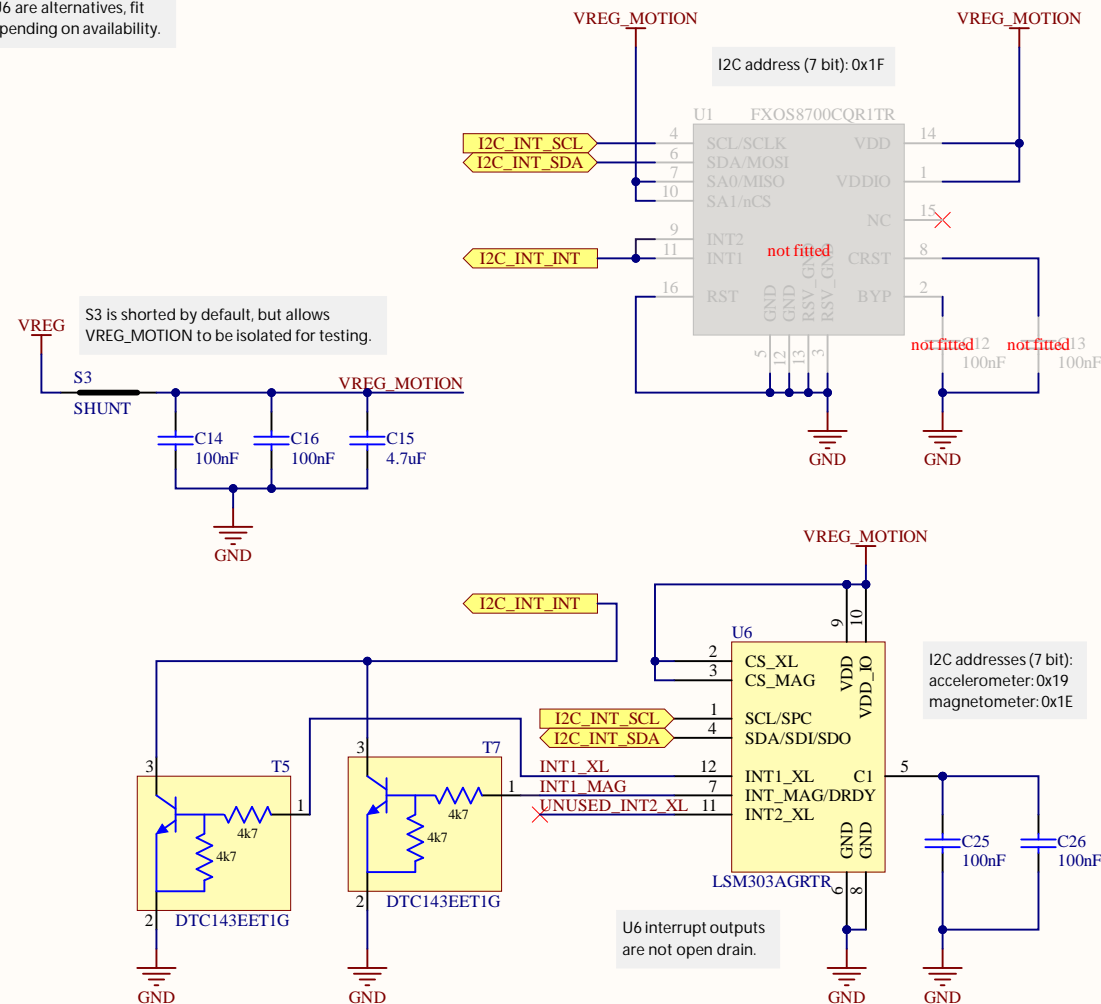

## LED matrix

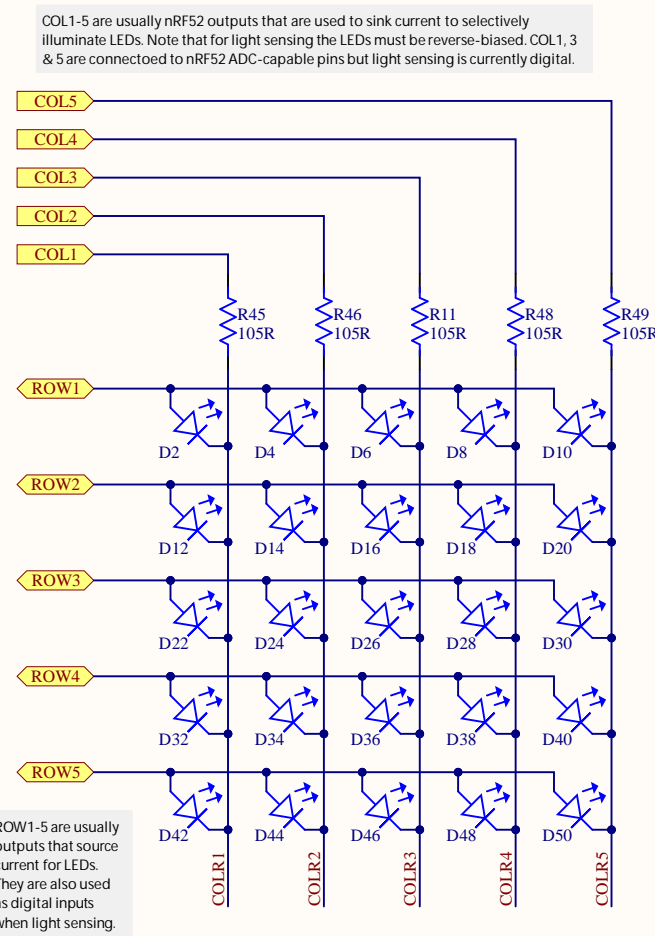

## Expansion connector

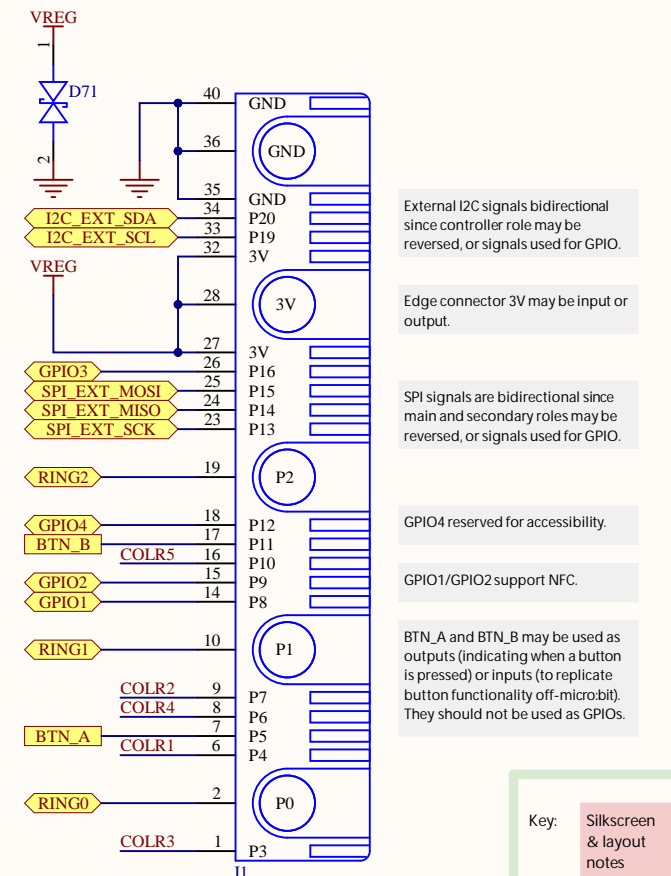

Key:  
  Silkscreen & layout notes  
  Block name  
  Design notes

# Target MCU

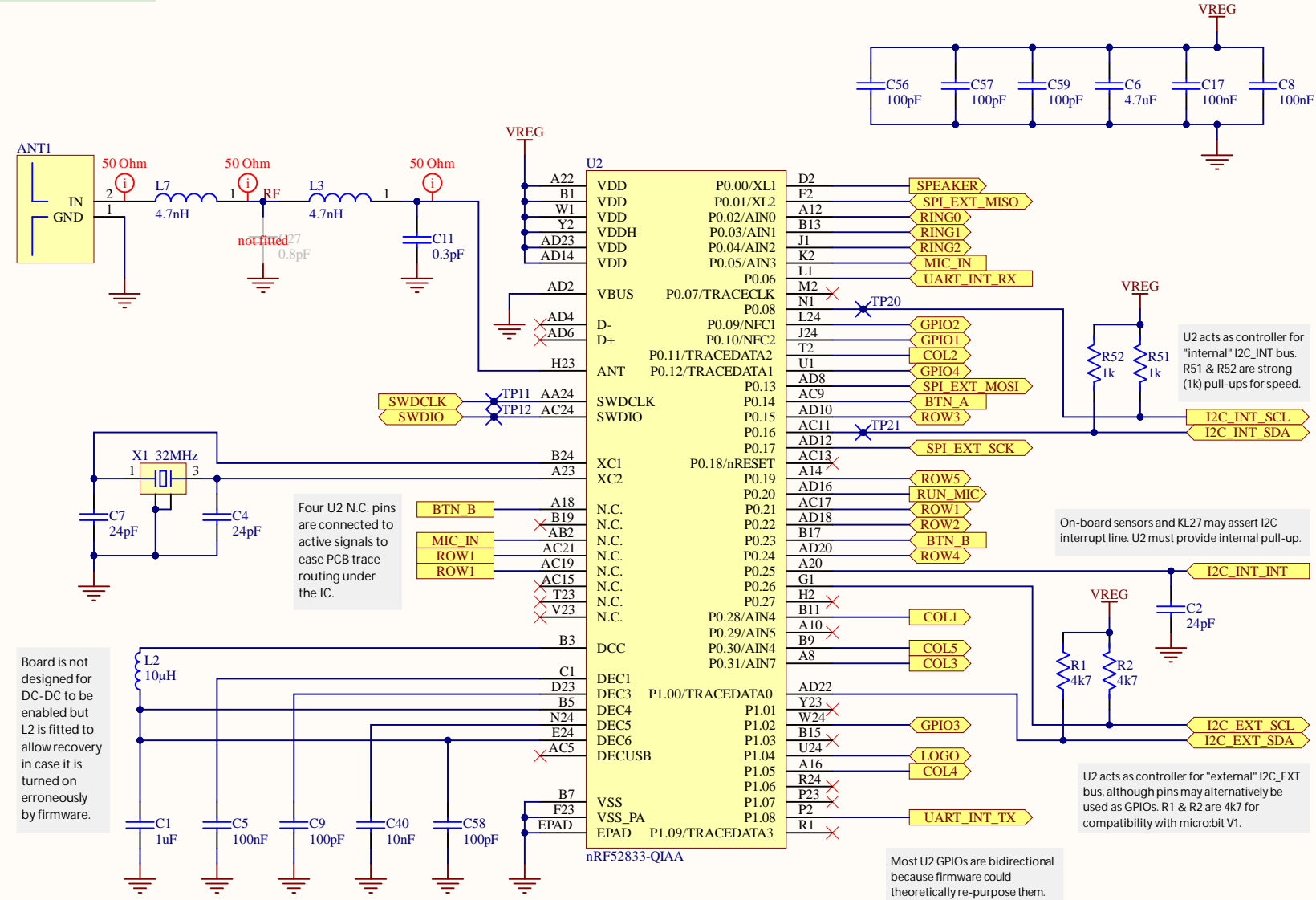

Key:

- Silkscreen & layout notes
- Block name
- Design notes